

# SINGLE LINE REEF

## Instant reefing with Single Line Reef

Single Line Reef is made practical and reliable by Seldén. All you do is ease off the halyard to premarked reefing points and then haul in on the reefing line. The luff and the leech are reefed at the same time. A system of guided blocks inside the boom ensures that the lines do not tangle. The system has a 2:1 gear ratio, making reefing fast and simple, without having to leave the cockpit.

### Single Line Reef booms

Art. No.	Boom section	E <sub>max</sub> mm	Remarks
BS 087-61	B087	3410	Outhaul (2:1) + 2 Single Line Reef, aft
BS 104-61	B104	3560	Outhaul (2:1) + 2 Single Line Reef, aft
BS 104-62		4060	Outhaul (2:1) + 2 Single Line Reef, aft
BS 120-62	B120	3635	Outhaul (3:1) + 2 Single Line Reef, aft
BS 120-63		4135	Outhaul (3:1) + 2 Single Line Reef, aft
BS 135-62	B135	4105	Outhaul (3:1) + 2 Single Line Reef, aft
BS 135-63		4605	Outhaul (3:1) + 2 Single Line Reef, aft
BS 152-62	B152	4305	Outhaul (3:1) + 2 Single Line Reef, aft
BS 152-63		4605	Outhaul (3:1) + 2 Single Line Reef, aft
BS 152-64		5105	Outhaul (3:1) + 2 Single Line Reef, aft
BS 152-65		5605	Outhaul (3:1) + 2 Single Line Reef, aft
BS 171-61B	B171	4625	Outhaul (3:1) + 2 Single Line Reef, aft
BS 171-62B		5125	Outhaul (3:1) + 2 Single Line Reef, aft
BS 171-63B		5625	Outhaul (3:1) + 2 Single Line Reef, aft
BS 171-64B		6225	Outhaul (3:1) + 2 Single Line Reef, aft
BS 200-61B	B200	5665	Outhaul (4:1) + 2 Single Line Reef, aft
BS 200-62B		6765	Outhaul (4:1) + 2 Single Line Reef, aft
BS 250-61B	B250	5670	Outhaul (4:1) + 2 Single Line Reef, aft
BS 250-62B		6170	Outhaul (4:1) + 2 Single Line Reef, aft
BS 250-63B		7170	Outhaul (4:1) + 2 Single Line Reef, aft
BS 250-64B		7670	Outhaul (4:1) + 2 Single Line Reef, aft

Aft = Lines to cockpit.

### Inboard end

Boom section	A mm	B mm	C mm
B087	8	8	16
B104	8	8	16
B120	14	10	20
B135	14	12	20
B152	14	12	20
B171	16	12	20
B200	20	16	30
B250	18	16	30

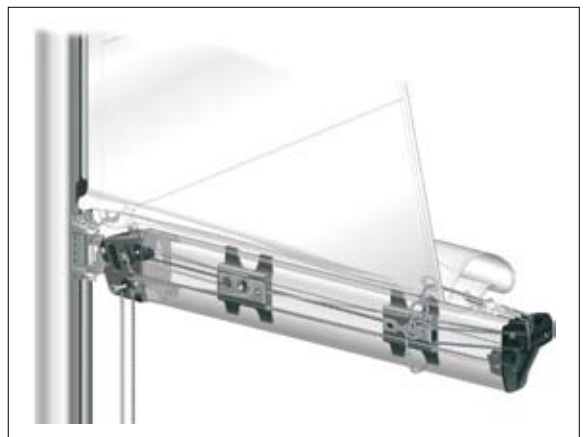
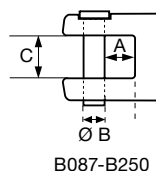

Single Line Reef. Pulls down luff and leech at the same time. Operated from the safety of the cockpit.

# How to operate a Single Line boom



*Release the Rodkicker.*



*Slacken the mainsheet.*



*Ease off the main halyard to premarked reefing points.*



*Tension the reef line up to the marked position the line.*



*The reef is in.  
Remove any slack in other reefs.*



*Adjust the mainsheet.*



*Adjust the Rodkicker.*



*It's as simple as that!*

# Boom sections choice

To select the correct boom section, you will need to know the sail foot length (E) and righting moment (RM). If the RM is not known, displacement is an alternative.

The E and Y measurements must also be known for dimensioning purposes. The length of the boom is sometimes determined by other factors than E and therefore we need the S measurement aswell. A good example is when the boom extrusion needs an over-length to allow the main sheet to pass a sprayhood.

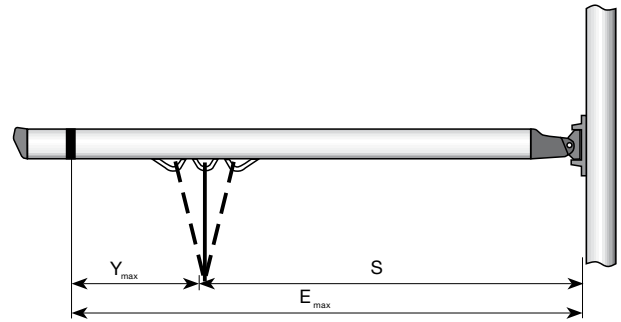

## Masthead rigs, $E_{max}$ and $Y_{max}$ (m)

Section	RM 30° kNm	Displ. tonnes	B087		B104		B120		B135		B152		B171		B200		B250		B300	
			$E_{max}$	$Y_{max}$	$E_{max}$	$Y_{max}$	$E_{max}$	$Y_{max}$	$E_{max}$	$Y_{max}$	$E_{max}$	$Y_{max}$	$E_{max}$	$Y_{max}$	$E_{max}$	$Y_{max}$	$E_{max}$	$Y_{max}$	$E_{max}$	$Y_{max}$
6	1.2		3.4	1.7	4.1	1.8	4.1	2.1												
8	1.6		3.4	1.4	4.1	1.6	4.1	1.8	4.6	2.5										
10	2.0		3.3	1.3	4.1	1.4	4.1	1.6	4.6	2.2										
12	2.4		2.9	1.2	4.0	1.3	4.1	1.5	4.6	2.0	5.6	2.9								
14	2.8		2.6	1.1	3.5	1.2	4.1	1.4	4.6	1.9	5.6	2.7								
16	3.2				3.2	1.1	4.1	1.3	4.6	1.8	5.6	2.5	6.1	3.3						
18	3.6				3.0	1.1	4.1	1.2	4.6	1.7	5.6	2.4	6.1	3.1						
20	4.0				2.8	1.0	3.8	1.1	4.6	1.6	5.6	2.3	6.1	3.0						
25	5.0				2.4	0.9	3.3	1.0	4.6	1.4	5.6	2.0	6.1	2.7						
30	5.7						2.9	0.9	4.5	1.3	5.6	1.9	6.1	2.4	6.6	3.7				
35	6.3						2.6	0.9	4.0	1.2	5.6	1.7	6.1	2.3	6.6	3.4				
40	7.0								3.7	1.1	5.1	1.6	6.1	2.1	6.6	3.2				
45	7.7								3.4	1.1	4.7	1.5	6.1	2.0	6.6	3.0				
50	8.2								3.2	1.0	4.4	1.4	6.1	1.9	6.6	2.8				
55	9.0										4.1	1.4	6.1	1.8	6.6	2.7				
60	10										3.9	1.3	5.7	1.7	6.6	2.6				
70	11										3.5	1.2	5.1	1.6	6.6	2.4	7.6	3.7		
80	12										3.2	1.1	4.7	1.5	6.6	2.2	7.6	3.5		
90	14										2.9	1.1	4.3	1.4	6.5	2.1	7.6	3.3		
100	15										2.7	1.0	4.0	1.3	6.0	2.0	7.6	3.1		
110	16												3.7	1.3	5.7	1.9	7.6	3.0		
120	18												3.5	1.2	5.3	1.8	7.6	2.8	8.3	4.1
130	19												3.3	1.2	5.0	1.8	7.6	2.7	8.3	3.9
140	20												3.2	1.1	4.8	1.7	7.6	2.6	8.3	3.8
150	22														4.6	1.6	7.5	2.5	8.3	3.7
160	23														4.4	1.6	7.2	2.5	8.3	3.5
170	25														4.2	1.5	6.9	2.4	8.3	3.4
180	26														4.0	1.5	6.6	2.3	8.3	3.3
190	27														3.9	1.5	6.4	2.3	8.3	3.2
200	28														3.7	1.4	6.1	2.2	8.3	3.2
210	30																5.9	2.1	8.3	3.1
220	31																5.7	2.1	8.3	3.0
230	32																5.6	2.1	8.3	2.9
240	34																5.4	2.0	8.3	2.9
250	35																5.2	2.0	8.3	2.8



### Fractional rigs, $E_{max}$ and $Y_{max}$ (m)

Section	RM 30° kNm	Displ. tonnes	B087		B104		B120		B135		B152		B171		B200		B250		B300	
			$E_{max}$	$Y_{max}$	$E_{max}$	$Y_{max}$	$E_{max}$	$Y_{max}$	$E_{max}$	$Y_{max}$	$E_{max}$	$Y_{max}$	$E_{max}$	$Y_{max}$	$E_{max}$	$Y_{max}$	$E_{max}$	$Y_{max}$	$E_{max}$	$Y_{max}$
6	1.2	3.4	1.4	4.1	1.6	4.1	1.8													
8	1.6	3.3	1.2	4.1	1.4	4.1	1.6	4.6	2.1											
10	2.0	2.8	1.1	3.7	1.2	4.1	1.4	4.6	1.9											
12	2.4	2.5	1.0	3.3	1.1	4.1	1.3	4.6	1.8											
14	2.8	2.2	0.9	3.0	1.0	4.1	1.2	4.6	1.6	5.6	2.3									
16	3.2	2.0	0.9	2.7	1.0	3.7	1.1	4.6	1.5	5.6	2.1									
18	3.6			2.5	0.9	3.4	1.0	4.6	1.4	5.6	2.1	6.1	2.7							
20	4.0					3.2	1.0	4.6	1.4	5.6	2.0	6.1	2.6							
25	5.0					2.7	0.9	4.3	1.2	5.6	1.7	6.1	2.3	6.6	3.4					
30	5.7							3.8	1.1	5.2	1.6	6.1	2.1	6.6	3.1					
35	6.3							3.4	1.0	4.7	1.5	6.1	1.9	6.6	2.9					
40	7.0							3.1	1.0	4.3	1.4	6.1	1.8	6.6	2.7					
45	7.7									3.9	1.3	5.8	1.7	6.6	2.6					
50	8.2									3.7	1.2	5.4	1.6	6.6	2.4					
55	9.0									3.4	1.2	5.1	1.5	6.6	2.3	7.6	3.6			
60	10									3.2	1.1	4.8	1.5	6.6	2.2	7.6	3.5			
70	11									2.9	1.0	4.3	1.4	6.5	2.1	7.6	3.2			
80	12											3.9	1.3	5.9	1.9	7.6	3.0			
90	14											3.6	1.2	5.4	1.8	7.6	2.8			
100	15											3.3	1.1	5.0	1.7	7.6	2.7	8.3	3.9	
110	16											3.1	1.1	4.7	1.6	7.6	2.6	8.3	3.7	
120	18													4.4	1.6	7.3	2.4	8.3	3.5	
130	19													4.2	1.5	6.9	2.3	8.3	3.4	
140	20													4.0	1.5	6.6	2.3	8.3	3.3	
150	22													3.8	1.4	6.2	2.2	8.3	3.1	
160	23													3.6	1.4	6.0	2.1	8.3	3.0	
170	25													3.5	1.3	5.7	2.1	8.3	3.0	
180	26													3.3	1.3	5.5	2.0	8.3	2.9	
190	27													3.2	1.3	5.3	1.9	8.3	2.8	
200	28														5.1	1.9	8.2	2.7		
210	30														4.9	1.8	7.9	2.7		
220	31														4.8	1.8	7.7	2.6		
230	32														4.6	1.8	7.4	2.5		
240	34														4.5	1.7	7.2	2.5		
250	35														4.4	1.7	7.0	2.4		

**SELDÉN and FURLEX are registered trademarks of Seldén Mast AB**

**Seldén Mast AB, Sweden** Tel +46 (0)31 69 69 00. Fax +46 (0)31 29 71 37. e-mail [info@seldenmast.com](mailto:info@seldenmast.com)

**Seldén Mast Limited, UK** Tel +44 (0)1329 50 40 00. Fax +44 (0)1329 50 40 49. e-mail [info@seldenmast.co.uk](mailto:info@seldenmast.co.uk)

**Seldén Mast Inc., USA** Tel +1 843-760-6278. Fax +1 843-760-1220. e-mail [info@seldenus.com](mailto:info@seldenus.com)

**Seldén Mast A/S, Denmark** Tel +45 39 18 44 00. Fax +45 39 27 17 00. e-mail [info@seldenmast.dk](mailto:info@seldenmast.dk)

**Seldén Mid Europe B.V., Netherlands** Tel +31 (0) 111-698 120. Fax +31 (0) 111-698 130. e-mail [info@seldenmast.nl](mailto:info@seldenmast.nl)

**Seldén Mast, France** Tel +33 (0) 251 362 110. Fax +33 (0) 251 362 185. e-mail [info@seldenmast.fr](mailto:info@seldenmast.fr)

[www.seldenmast.com](http://www.seldenmast.com)

 **SELDÉN**  
for sailing